

IMPLEMENTATION OF AREA, VOLUME AND LINE SOURCES

The Met. Office (D J Thomson) and CERC

1. INTRODUCTION

ADMS models line sources, and area and volume sources with convex polygon base areas. The algorithm treats all three source types in a similar way, but the source geometries must be defined in the following ways by the user:

- (i) **line sources** - positions of the end points of the line (X_1, Y_1) and (X_2, Y_2) , Z_s the height of the source and L_L the width of the line. Line sources are assumed to be horizontal (the height of the end points the same) and must have widths greater than 0.001m, see Figure 1.
- (ii) **area sources** - (X_n, Y_n) , $n=1,2,3\dots$ are the locations of the vertices of the convex polygon defining the base area of the source and Z_s the height of the source. It is assumed that the base area of an area or volume source lies in a horizontal plane. The base area may have from 3 to 50 vertices.
- (iii) **volume sources** - (X_n, Y_n) , $n=1,2,3\dots$ are the locations of the vertices defining the base cross-section of the volume source as for the area source. L_V is the vertical extent (depth) of the volume source and the source height Z_s is $0.5L_V$ above the base i.e. Z_s is the mid-height of the source, see Figure 2.

The calculation scheme used in ADMS for line, area and volume sources is outlined in Section 2, below, and described in more detail in Sections 3 and 4. Section 5 describes the treatment of plume rise. Calculations in low wind conditions are described in Section 6.

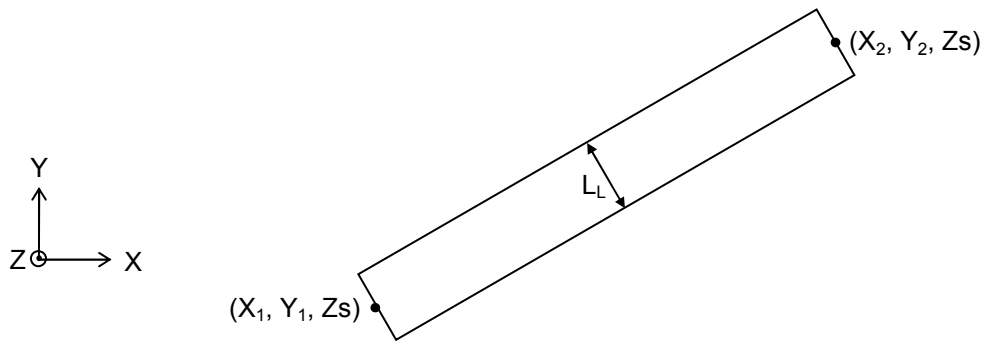

Figure 1 Definition of a line source

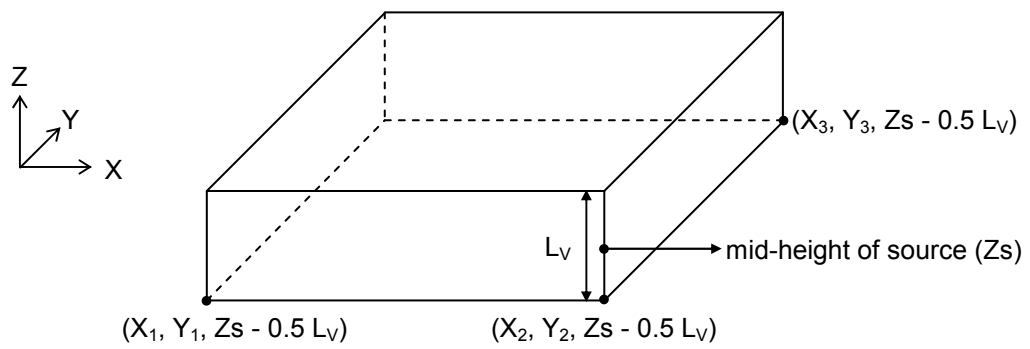

Figure 2 Definition of a volume source

2. OUTLINE OF SCHEME

Note that the expression used in ADMS for calculating concentrations from a *point* source is as follows. Taking coordinates centred on a point source at $(0, 0, Z_s)$, with x in the downwind direction, the concentration C is given by

$$C(x, y, z) = \frac{Q_s}{2\pi\sigma_y\sigma_zU} \exp\left(\frac{-y^2}{2\sigma_y^2}\right) \exp\left(\frac{-(z-z_s)^2}{2\sigma_z^2}\right) + \text{reflection terms.} \quad (1)$$

where σ_y and σ_z are the plume spread parameters in the crosswind and vertical directions in metres respectively, U is the wind speed in m/s and Q_s is in mass units/s.

For *line*, *area* and *volume* sources, the concentration is calculated as follows.

The source is decomposed into a number of source elements, the decomposition being a function of the receptor location. The difference in streamwise distance between source elements and each receptor is constrained not to vary too rapidly, subject to the maximum number of source elements.

The concentration is then calculated by summing the contributions from each element. In the case of a line or area source, the contribution from each element is approximated by a crosswind line source of finite length. The expression for the concentration, $\bar{C}(x, y, z)$, from a finite crosswind line source of length L_s is given by equation (2). The source strength, \bar{Q}_s , is in mass units/m/s.

$$\bar{C}(x, y, z) = \frac{\bar{Q}_s}{2\sqrt{2}\pi\sigma_zU} \exp\left(-\frac{(z-z_s)^2}{2\sigma_z^2}\right) \times \left[\operatorname{erf}\left(\frac{y+L_s/2}{\sqrt{2}\sigma_y}\right) - \operatorname{erf}\left(\frac{y-L_s/2}{\sqrt{2}\sigma_y}\right) \right] + \text{reflection terms} \quad (2)$$

Similarly, for a volume source, the contribution from each element is approximated by a crosswind vertical slice of finite length and height. The expression for the concentration $\bar{\bar{C}}(x, y, z)$ from a crosswind vertical slice of length L_s and height L_V is given by equation (3). The source strength $\bar{\bar{Q}}_s$ is in mass units/m²/s.

$$\bar{\bar{C}}(x, y, z) = \frac{\bar{\bar{Q}}_s}{4U} \left[\operatorname{erf}\left(\frac{y+L_s/2}{\sqrt{2}\sigma_y}\right) - \operatorname{erf}\left(\frac{y-L_s/2}{\sqrt{2}\sigma_y}\right) \right] \times \left[\operatorname{erf}\left(\frac{z+L_V/2-z_s}{\sqrt{2}\sigma_z}\right) - \operatorname{erf}\left(\frac{z-L_V/2-z_s}{\sqrt{2}\sigma_z}\right) \right] + \text{reflection terms} \quad (3)$$

The steps in the calculation are:

For each meteorological condition:

- (i) Calculate the near-field spreading rate at the mean plume height, σ_{y10} , from the lateral

spread 10 m downwind from a point source i.e. $\sigma_{y10} = \sigma_y(z=z_m, x=10 \text{ m})/10$. This calculation will include plume rise if the source has non-zero plume rise characteristics.

Then for each output point:

- (ii) Remove redundant parts of the source that cannot possibly contribute to the calculated concentrations, based on the spreading rate σ_{y10} , see §3.1
- (iii) Decompose the source into source elements, see §3.2
- (iv) Replace each of these source elements with a cross-wind line source of equivalent source strength, see §3.3
- (v) Calculate the concentration by summing over the source elements using equation (2).

These steps are described in more detail in Section 3.

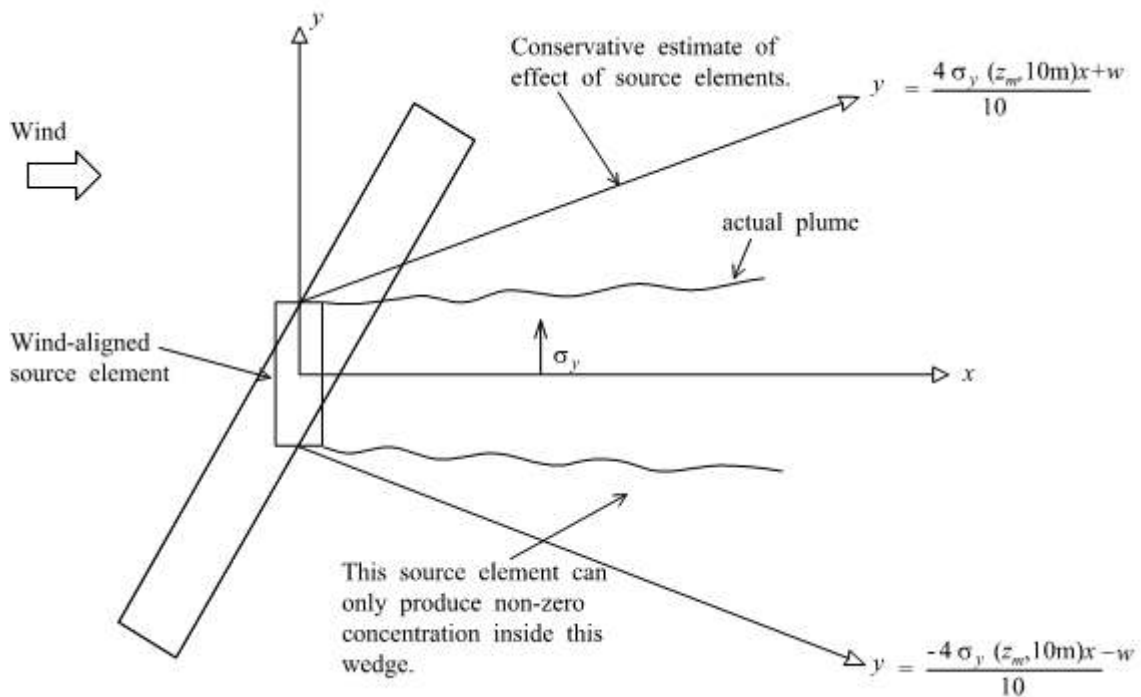

Figure 3 Domain of influence of source element in flat terrain. w is the half width of the wind aligned element.

3. DESCRIPTION OF CALCULATION

3.1 Removing redundant parts of the source

Often, when considering a long line or a large area or volume source there will be parts of the source which give a negligible contribution to the concentration at a given output position due to their large crosswind distance from the output point. To speed up the calculation such parts of the source are trimmed and neglected in the calculation for flat terrain, or modelled at low resolution for complex terrain. The model makes the conservative assumption that a part of the source gives a negligible contribution at output positions that are more than $4\sigma_{y,10}$ distant in the crosswind direction from the streamline through that part of the source. This is shown in Figure 3. Applying this condition can have the effects shown in Figures 4 and 5.

3.2 Decomposing the source

In order to treat a line/area/volume source as a sum of crosswind line sources it is necessary to decompose the source into crosswind elements which can have different lengths and widths. Those nearest the output point have the smallest along-wind width and the elements furthest away will have the greatest along-wind width. This is in order to reduce the fractional error in the along-wind source to receptor distance. (Ideally the elements would have negligible along wind width to approximate to a zero width line source.) A limit of 10 source elements per output point is used for the 'trimmed' source, with an additional 2 per source end in complex terrain, to balance accuracy and computing time. These limits were determined by sensitivity studies.

The program decomposes the source for each different met condition and for each different output point. It attempts to use source elements in which the along wind distance between adjacent elements changes by no more than 10%. Larger changes are used in some situations in order to obey the limit on the number of elements. These circumstances usually only happen for a few output points which are very close to, or inside the source. The decomposition routine works in wind-aligned co-ordinates with the x -axis pointing downwind.

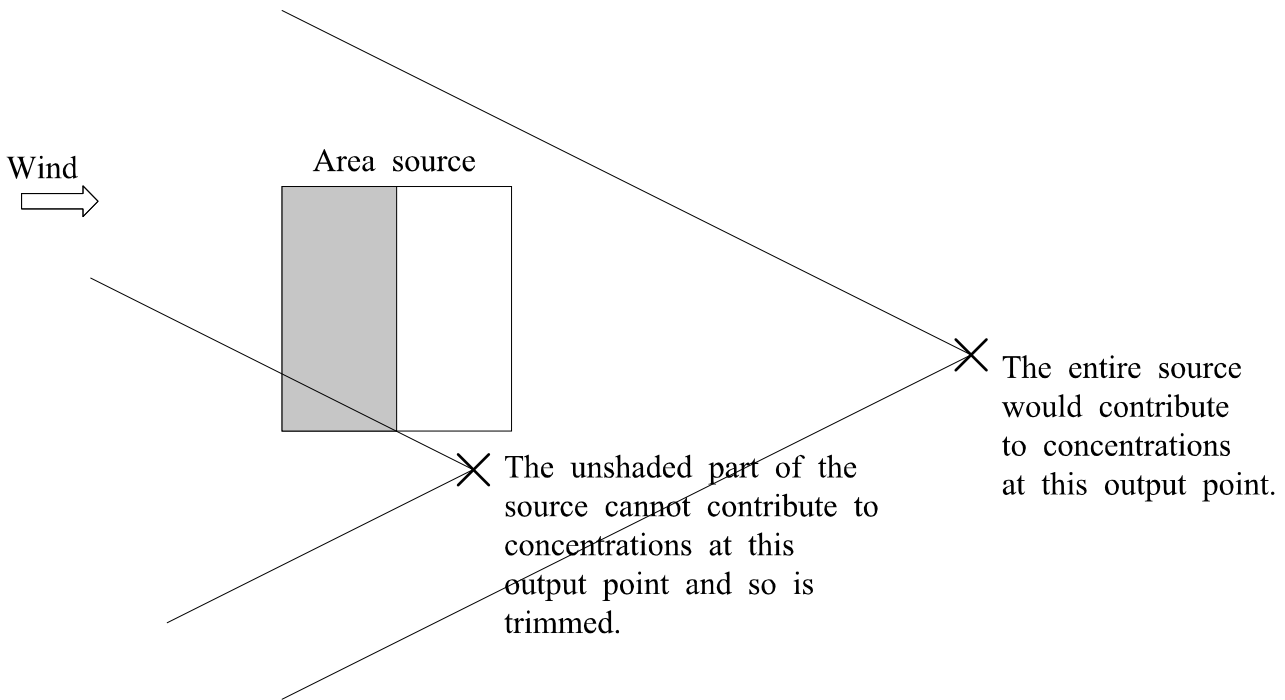

Figure 4 The effect of “trimming” an area source

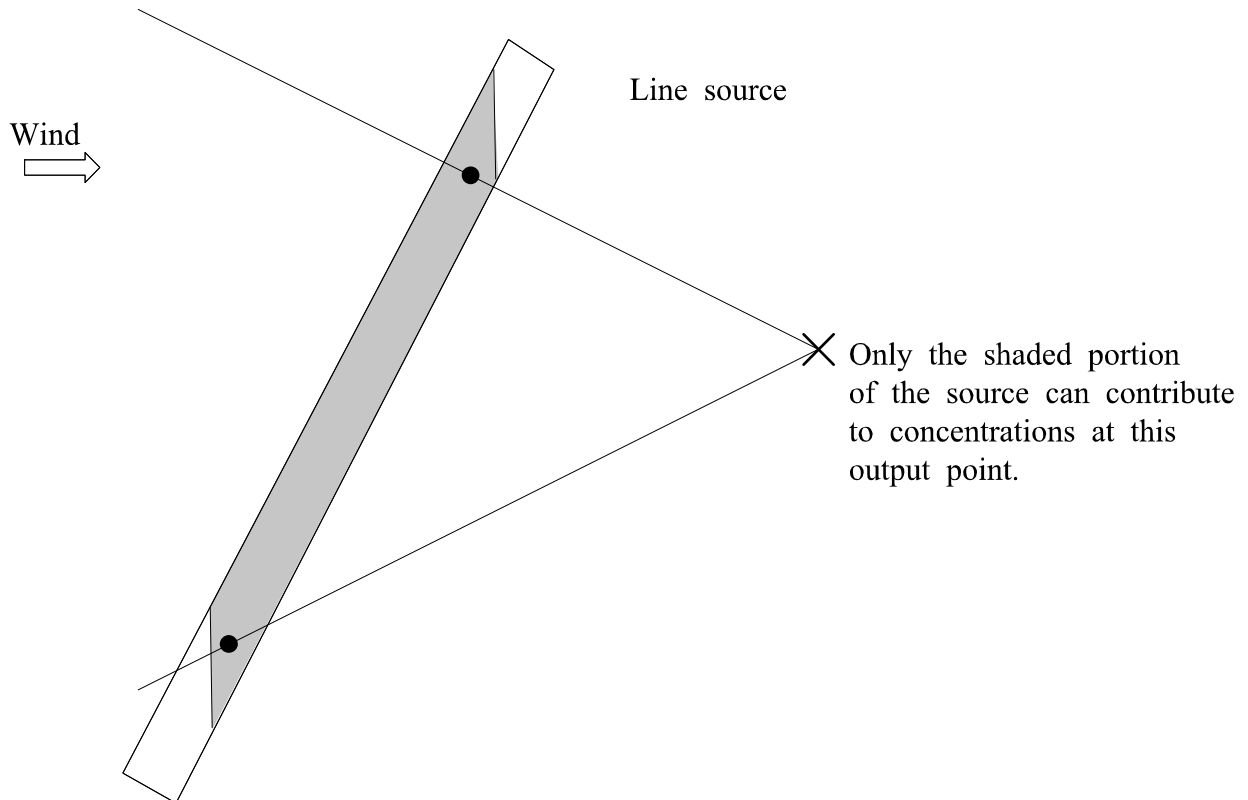

Figure 5 The effect of “trimming” on a line source

From Section 3 we can assume that the parts of the source which need to be included in the decomposition all lie between some x_{\min} and some x_{\max} ($x_{\min} < x_{\max}$) and that x_{\min} is upwind of the output position x_r , ($x_{\min} < x_r$) For each source x_{\min} and x_{\max} are selected from: the most upwind point of the untrimmed source, the most downwind point of the untrimmed source, and the point where the lines $\pm 4\sigma_y(z_m, 10 \text{ m})x/10 \text{ m}$ cross a side of the source (if they do).

The next step is to divide the region up into n elements with centres x_{si} , $i = 1, n$. The source is cut at the points x_i , $i=0,1,2\dots n$, where $x_0 = x_{\min}$, $x_n = x_{\max}$, to create the n source elements. The distance from the receptor to one cut and the distance from the receptor to the adjacent cut changes by no more than a fraction λ i.e.

$$\frac{x_r - x_i}{x_r - x_{i-1}} = (1 - \lambda) \quad (4)$$

and hence

$$x_i = x_r - (x_r - x_{\min}) (1 - \lambda)^i \quad (5)$$

Since $x_n = x_{\max}$ we have

$$\lambda = 1 - \left(\frac{x_r - x_{\max}}{x_r - x_{\min}} \right)^{1/n} \quad (6)$$

Increasing n can ensure that λ is less than 0.1.

3.3 Replacing the source elements with crosswind line sources

Once the centres of the source elements x_{si} have been found it is a matter of geometry to find the appropriate values for the area of the source element, A_i , the cross-wind length of each line source L_i , and the source strength per unit length $Q_{l,i}$ of the line sources. For the configuration shown in Figure 6 these have a simple form:

$$A_i = (x_i - x_{i-1})L_i \quad (7)$$

$$L_i = 0.5(y_{i,2} + y_{i-1,2}) - 0.5(y_{i,1} + y_{i-1,1}) \quad (8)$$

and

$$Q_{l,i} = \frac{A_i Q_l}{L_i} \quad (9)$$

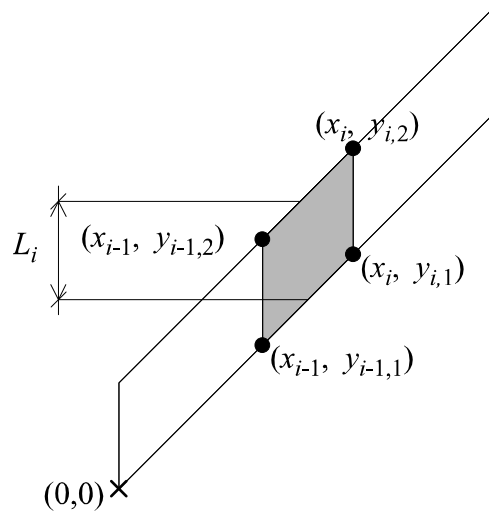

Figure 6 Replacing source elements with crosswind line sources. The shaded area is the part of the source which has been replaced by a crosswind line source of length L_i .

4. VOLUME SOURCES

The method of calculation of the concentration field due to a volume source is the same as that due to a line or area source apart from the source elements used are crosswind vertical slices instead of crosswind line sources. The concentration distribution for a vertical slice with vertices $(0, -L_s/2, z_s - L_v/2)$, $(0, -L_s/2, z_s + L_v/2)$, $(0, L_s/2, z_s - L_v/2)$ and $(0, L_s/2, z_s + L_v/2)$ is given by equation (3).

Volume sources do not have any plume rise.

5. PLUME RISE

The plume rise model (P11/02) is used to calculate plume rise from all source types including line and area sources.

Specification P11/02 describes how in practice the buoyancy and momentum flux from a *ground level* source must exceed certain thresholds for the emission to lift off from ground. In ADMS the following thresholds are used for ground level line and area sources:

$$F_M > 2 \text{ or } F_B > 0.01 \quad (10)$$

where F_M and F_B are the non-dimensional momentum and buoyancy fluxes respectively:

$$F_M = \frac{\rho_s w^2}{\rho_a U^2} \quad (11)$$

$$F_B = \frac{g\pi D w (\rho_a - \rho_s)}{4\rho_a U^3} \quad (12)$$

w is the emission velocity, ρ_s the emission density, ρ_a the density of the ambient air and U the wind speed at 10 m. D is a source dimension. For an area source it is the square root of the source area and for a line source it is the minimum dimension, which will usually be the line width rather than the line length.

For area sources that are large in cross-section the assumption used here, that the emission behaves like one plume, if it has sufficient momentum and buoyancy, is not well approximated. The emission will not in practice behave as a single bent over plume.

The default value for the emission velocity or volume flow rate from a line or area source in the model interface is zero which turns off the plume rise module. This default value has been adopted to reflect the fact that in practice such sources e.g. road traffic, quarries, will not usually have significant plume rise.

6. SPECIAL TREATMENT IN LOW WIND CONDITIONS

Section 5 of Technical Specification document P10/12 describes the special treatment of point sources in low wind conditions. A similar treatment applies to line, area and volume sources. The final concentration due to a line, area or volume source is a weighted average between the normal 'gaussian' concentration C_g and a 'radial' concentration C_r , where the weighting is a function of the wind speed at 10 m.

To calculate C_r , the source is represented as a series of radially-symmetric passive point sub-sources, each with source height equal to the maximum plume height from the normal line/area/volume plume rise calculations. The concentration due to each component sub-source is calculated according to equation (5.1) from P10/12:

$$C_r^i = \frac{Q_s}{\sqrt{2\pi}\sigma_z(2\pi r)U} \left\{ \exp\left(\frac{-(z-z_s)^2}{2\sigma_z^s}\right) + \exp\left(\frac{-(z+z_s)^2}{2\sigma_z^s}\right) + \exp\left(\frac{-(z-2h+z_s)^2}{2\sigma_z^s}\right) \right. \\ \left. + \exp\left(\frac{-(z+2h-z_s)^2}{2\sigma_z^s}\right) + \exp\left(\frac{-(z-2h-z_s)^2}{2\sigma_z^s}\right) \right\}$$

where r is the perpendicular distance from the sub-source to the current receptor.

The total value of C_r for a particular receptor is the sum of C_r^i over all sub-sources.

The source is decomposed (for each receptor) into a series of point sub-sources using a similar approach to that described in §3, with the following differences:

- All of the source is included in the decomposition of the source into crosswind line sources. This means that the receptor may lie within the source. In this case the maximum number of cuts allowed is distributed proportionately between the upstream and downstream portions of the source and each portion is decomposed separately with the finest spacing closest to the receptor.

- Once the source has been decomposed into crosswind line sources, each crosswind line source is further decomposed into up to 10 area sources, using the same decomposition algorithms, each of which are then approximated as a point source.

7. NOTATION

A_i	area of a source element (m^2)
$\bar{C}(x,y,z)$	ensemble mean concentration at output point (x,y,z)
D	horizontal dimension of line or area source
F_B	buoyancy flux of the emission
F_M	momentum flux of the emission
g	acceleration due to gravity
L_L	width of a line source (m)
L_V	vertical extent (depth) of a volume source (m)
L_i	cross-wind width of a source element (m)
Q_l	source mass emission rate per unit length (mass units/s/m)
$Q_{l,i}$	source element mass emission rate per unit length (mass units/s/m)
U	wind speed in m/s at 10m
w	half width of source element (m)
x	downwind distance (m)
x_i	downwind location of i^{th} cut (m)
x_{si}	downwind location of centre of source element i (m)
x_{min}	downwind location of the most upwind point of the trimmed source (m)
x_{max}	downwind location of most downwind point of the trimmed source (m)
x_r	downwind location of receptor (m)
y	crosswind distance (m)
z	vertical height (m)
z_s	source height (m)
z_0	surface roughness
ρ_a	density of ambient air
ρ_s	density of the emission
σ_{y10}	near-field spreading rate at the mean plume height, 10m downwind of a point source (m)
$\sigma_y(x)$	horizontal plume spread in metres at downstream distance x
$\sigma_y(z,x)$	horizontal plume spread in metres at height z and at downstream distance x