

ADMS 4 Buildings Validation

Warehouse Fires Wind Tunnel Experiments

Cambridge Environmental Research Consultants
June 2007

1 Introduction

In 1996, results from the CERC Atmospheric Dispersion Model, ADMS 2 were validated against experimental wind tunnel data of dispersion from chemical warehouse fires [1]. The original experimental data used to validate the model were presented in a Building Research Establishment Client Report [2]. Here, results from ADMS 4.0 (version 4.0.2.0) are validated against these experimental data, and corresponding ADMS 3.3 (version 3.3.1.0) and ISC-Prime results are also presented. ISC-Prime contains the same buildings model that is in the AERMOD model which is why it is included here.

Section 2 describes the experimental set up used in the wind tunnel experiments. Section 3 describes the exact input used for the ADMS 4.0, ADMS 3.3 and ISC-Prime runs. The results are presented in Section 4 and a summary of the results is given in Section 5.

2 Experimental set up

For full details of the experimental set up used, please refer to the BRE Client Report [2]. The experiments were carried out at model scale, which was taken to be 1/150 of a full scale sized warehouse. Two warehouse dimensions were used for comparison purposes: a large and a small warehouse. **Figure 1** shows the building shapes used.

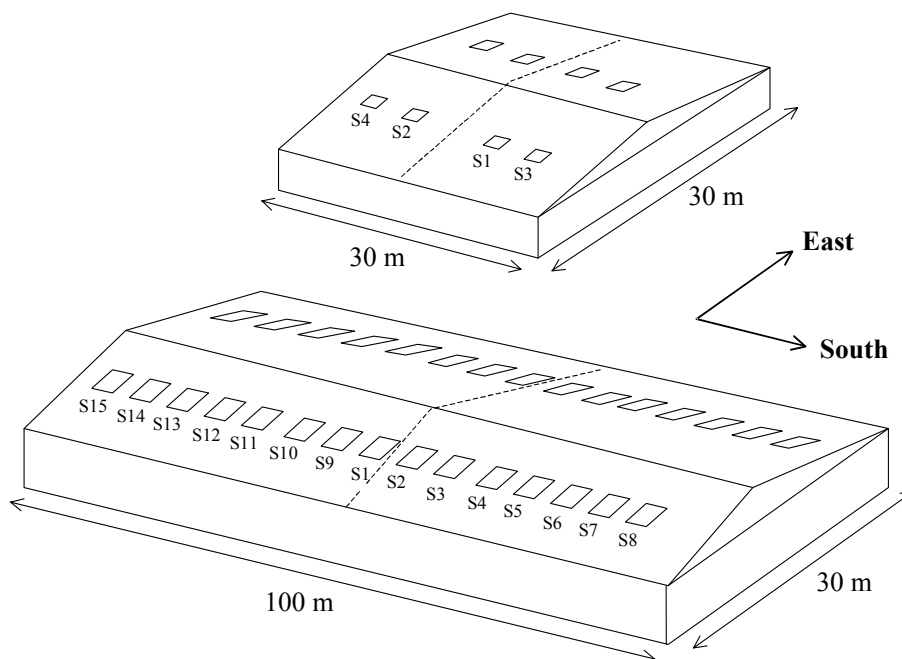

Figure 1 – The small building shape (top) and large building shape (bottom).

The roof openings were taken as the source of the smoke from the warehouse fire and the wind was taken as to be coming from the West. For both buildings, different numbers of roof openings were considered in separate experiments; that is, for the large building, the smoke was taken to come out of 1, 4, 9 and 15 openings, and for the small building, out of 1, 2 and 4 openings.

Three different buoyancy cases were considered. These are named as *Cases S, W and X*, and are summarized in **Table 1** (which is derived from to Table 2 in [2]). Here, the buoyancy flux parameter F_b is defined as

$$F_b = \frac{F}{U^3 L},$$

where U is the wind speed at reference height (taken to be the top of the building), L is the physical length scale of the experiment (taken to be the height of the building).

F is the buoyancy flux defined by

$$F = g \frac{\Delta\rho V}{\rho_a \pi},$$

where g is the acceleration due to gravity, ρ_a is the ambient gas density, ρ is the density of the smoke ($\Delta\rho = \rho_a - \rho$), and V is the volume emission rate of the discharged fire plume.

The momentum flux parameter F_m is defined as

$$F_m = \frac{\rho}{\rho_a} \frac{V w}{U^2 L^2},$$

where w is the fire plume gas exit velocity.

Case	Buoyancy flux parameter F_b	Momentum flux parameter F_m	Model wind speed U	Source diameter	Gas volume emission rate V
S	0	0	1	13	1
W	0.1	0.116	0.5	13	19.6
X	0.3	0.4	0.4	13	29.8

Table 1 – Experimental set up parameters (model scale). U in m/s, diameter in mm, volume emission rate in l/min.

Note

1. The exit velocities/volume emission rates entered into the model runs are calculated from the values in the gas volume emission rates indicated in **Table 1**, not from the momentum flux parameter F_m given in the table. There is a slight inconsistency here, in particular for Case S where a momentum flux of zero must correspond to a volume emission rate of zero. The values of F_m and V agree to within about 5% for Cases W and X.

2. The relationship between lengths for the model L_{mod} and full scale L_{fs} is

$$L_{fs} = 150 L_{\text{mod}},$$

which leads to the following relationship between model U_{mod} and full scale U_{fs} velocities:

$$U_{fs} = \sqrt{150} U_{\text{mod}}.$$

3 Input data

This section summarizes the data input into the ADMS 3.3 and ADMS 4.0 models. Data entered into the ISC-Prime model can be derived from the information here, and are therefore not given explicitly.

Note that all parameters given are for the full scale set up. Five sets of data are discussed: building data, source data, roughness length, meteorological data and output grid.

In addition, at the end of this section, a brief discussion on the adjustments made to the ADMS 3.3 and ADMS 4.0 code in order to model the wind tunnel boundary layer correctly is given.

3.1 Buildings

One building is modelled and the height is taken to be 10 m, which is the height of the building to the eaves. Other building parameters for the large and small building are given in **Table 2**.

Building	Height (m)	Length (m)	Width (m)	Angle (°)	Centre (m)
large	10	100	30	0	(-15, 0)
small	10	30	30	0	(-15, 0)

Table 2 – Building dimensions, orientation and location. The angle is the angle between north and the building length measured clockwise from north.

3.2 Sources parameters

The roof openings (sources) are shown in **Figure 1**. The locations of the 15 sources on the large building are given in **Table 3** and those of the 4 sources on the small building are given in **Table 4**.

Source	Location	Source	Location
S1	(-22.50, 0.00)	S9	(-22.50, 6.37)
S2	(-22.50, -6.37)	S10	(-22.50, 12.74)
S3	(-22.50, -12.74)	S11	(-22.50, 19.11)
S4	(-22.50, -19.11)	S12	(-22.50, 25.38)
S5	(-22.50, -25.38)	S13	(-22.50, 31.85)
S6	(-22.50, -31.85)	S14	(-22.50, 38.22)
S7	(-22.50, -38.22)	S15	(-22.50, 44.59)
S8	(-22.50, -44.59)		

Table 3 – Source locations for the large building.

Source	Location
S1	(-22.500, -3.195)
S2	(-22.500, 3.195)
S3	(-22.500, -9.585)
S4	(-22.500, 9.585)

Table 4 – Source locations for the small building.

For the large building, four different cases were considered: 1 roof opening (S1), 4 roof openings (S1-S3 and S9), 9 roof openings (S1-S5 and S9-S12) and 15 roof openings (S1-S15). For each case, an emission rate of 1 g/s was taken. That is for one opening, the source emission rate was 1 g/s whereas for 4 openings, each source has an emission rate of 0.25 g/s. Similarly, the volume flow rate/gas exit velocity (which varies for each of the Cases S, W and X) is divided equally between the sources. Sources are taken to be circular.

For the small building, three different cases were considered: 1 roof opening (S1), 2 roof openings (S1-S2) and 4 roof openings (S1-S4). Emission rates and volume flow rates were divided equally between the roof openings, as for the large building.

The remaining source input parameters are summarized in **Table 5**.

Case	Height (m)	Diameter (m)	Exit volume rate (m ³ /s)	Gas density (kg/m ³)	Emission rate (g/s)
S	10	1.95	4.593	1.225	1
W	10	1.95	90.02	0.222	1
X	10	1.95	136.9	0.212	1

Table 5 – Source parameters.

3.3 Roughness length

This was taken to be 0.3 m. Note that for the ISC-Prime model, the roughness length is not explicitly input. Instead the user has to choose between ‘RURAL’ and ‘URBAN’ dispersion parameters. As the ‘URBAN’ dispersion parameters correspond to a roughness length of approximately 0.4 m (according to the Environment Agency Technical Report [3]), this option was used to obtain the results presented here.

3.4 Meteorological data

The meteorological data are summarized in **Table 6**.

The definition of the surface sensible heat flux F_{θ} is not discussed here as it suffices to say that a value of $F_{\theta} = 0 \text{ W/m}^2$ corresponds to neutral atmospheric conditions (Pasquill-Gifford stability category D).

The height of the recorded wind was taken in all cases to be 10 m.

Case	Wind speed (m/s)	Wind direction (°)	Boundary-layer height (m)	Surface sensible heat flux (W/m ²)
S	12.25	270	82.5	0
W	6.12	270	82.5	0
X	4.90	270	82.5	0

Table 6 – Meteorological data.

3.5 Output grid

The output considered was at 15 locations downstream of the centre of building at locations $x = 9.375, 18.75, 37.5, 75, 112.5$ and then at 37.5 m intervals until $x = 487.5$ m.

3.6 Modifications made to the ADMS 3.3 and ADMS 4.0 codes

The boundary layer profile in a wind tunnel is approximately logarithmic, as in the atmospheric boundary layer. However, close to the surface, turbulence profiles in a wind tunnel are not typical of those observed in the atmosphere.

For this reason the boundary layer profiles in the ADMS 3.3 and ADMS 4.0 codes were modified slightly. For further details of the modifications made to the code, the reader is referred to Section 5 of the original ADMS Chemical Warehouse Fires validation paper [1].

Note that these modifications are not applicable to the ISC-Prime code, as turbulence profiles are not included in their plume dispersion model.

4 Results

For each of the three models (ADMS 3.3, ADMS 4.0 and ISC-Prime), there are 12 sets of experimental results for the large building and 9 sets for the small building. For each experiment, 15 data points are compared. The best way to display results such as these is statistically. The package used to calculate these statistics is the BOOT package [4].

The statistics are presented separately for the large and small building, and for buoyancy cases (S, W and X) and roof openings (1, 4, 9 and 15 for the large building; 1, 2 and 4 for the small building) in addition to the overall performance statistics.

As the experiment was performed at model scale, and the ADMS 3.3, ADMS 4.0 and ISC-Prime results are at full scale, statistics are calculated from the non-dimensional parameter K defined by

$$K = CUL^2/Q$$

where C is the concentration in g/m^3 , Q is the emission rate in g/s , and U and L are as defined in the Section 2.

4.1 Large building

Figure 2 gives the 5th, 25th, 50th, 75th and 95th percentiles of the ratio modelled to experimental values, for all runs divided into buoyancy cases.

Figure 3 gives shows the same set of results, but separated into number of roof openings.

Other statistics such as mean, variance (sigma), bias, normalized mean square error (NMSE), correlation (cor), values within a factor of 2 of the experimental values (fa2), fractional bias (fb) and fractional standard deviation (fs) are presented in the next tables, as output directly from the BOOT statistics package.

Table 7 gives the statistics divided into the buoyancy cases and **Table 8** gives the values divided into the number of openings. **Table 9** gives the summary statistics.

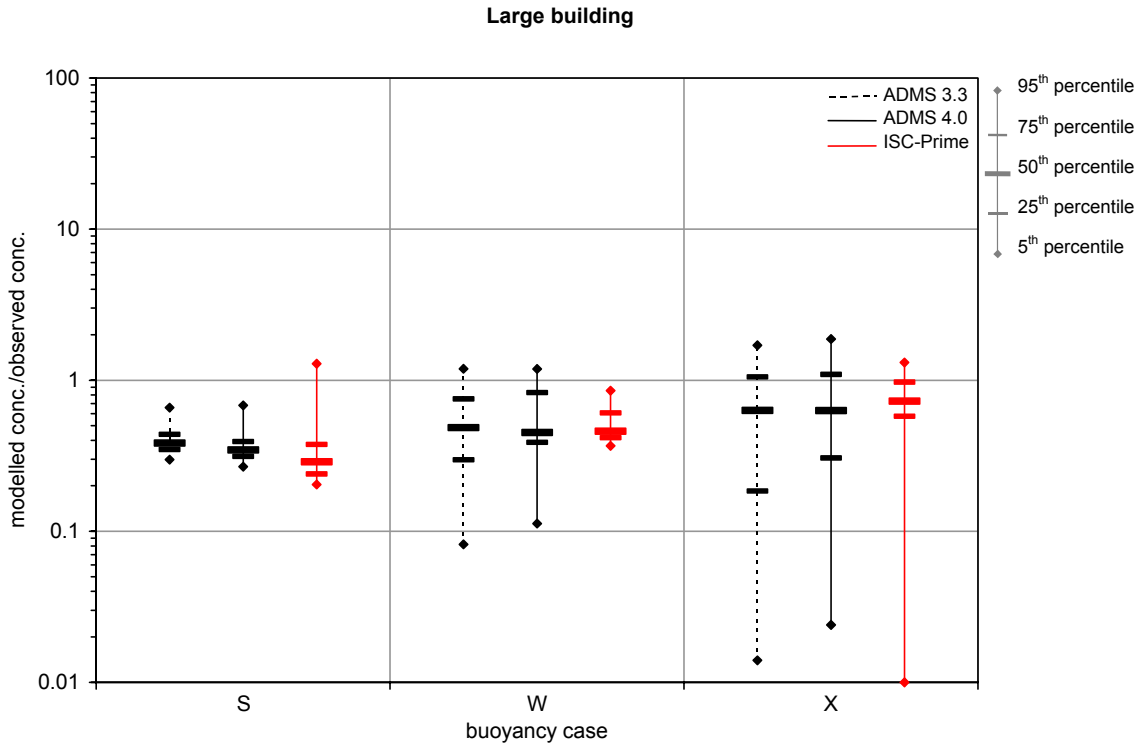

Figure 2 – Box and whisker plot of the results for the large building: buoyancy cases.

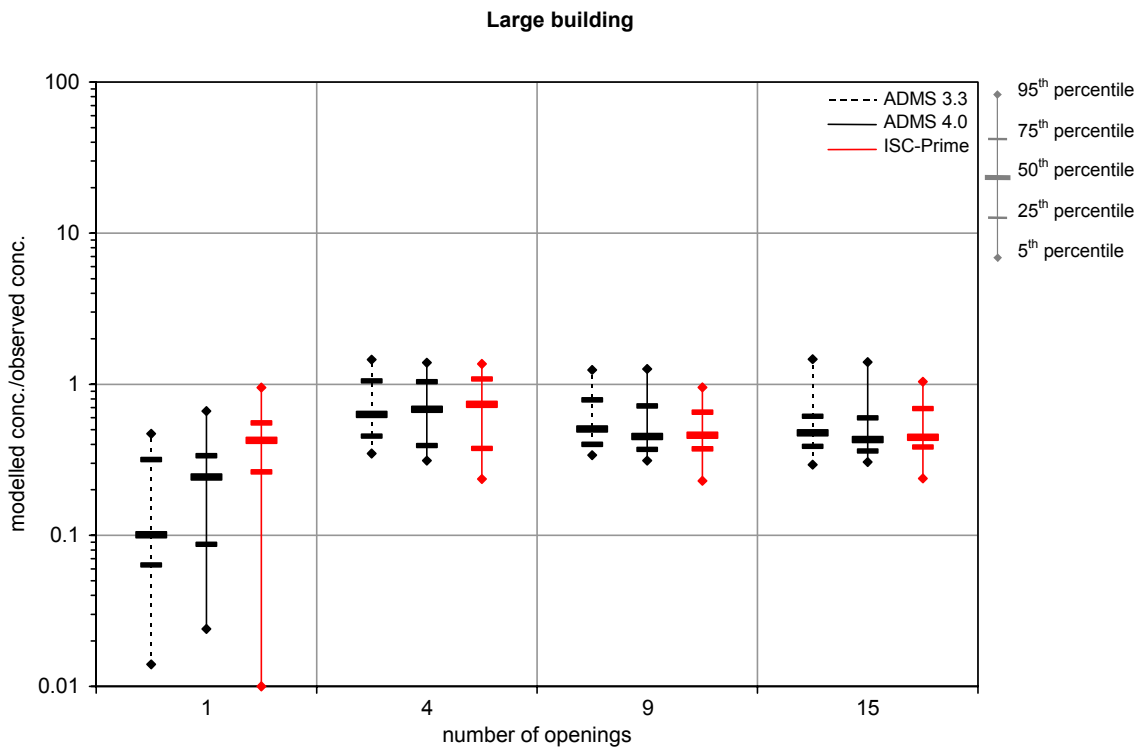

Figure 3 – Box and whisker plot of the results for the large building: roof openings.

Case	Data	Mean	Sigma	Bias	NMSE	Cor	Fa2	Fb	Fs
S	BRE (obs.)	1.00	0.83	0.00	0.00	1.000	1.000	0.000	0.000
	ADMS 3.3	0.46	0.47	0.54	1.00	0.943	0.133	0.734	0.547
	ADMS 4.0	0.44	0.49	0.56	1.09	0.935	0.133	0.775	0.516
	ISC-Prime	0.6	0.92	0.4	0.72	0.828	0.133	0.504	-0.096
W	BRE (obs.)	1.00	0.49	0.00	0.00	1.000	1.000	0.000	0.000
	ADMS 3.3	0.53	0.43	0.47	0.76	0.554	0.433	0.609	0.119
	ADMS 4.0	0.55	0.43	0.45	0.66	0.611	0.350	0.577	0.118
	ISC-Prime	0.58	0.43	0.42	0.46	0.795	0.400	0.535	0.125
X	BRE (obs.)	1.00	0.55	0.00	0.00	1.000	1.000	0.000	0.000
	ADMS 3.3	0.58	0.48	0.42	0.81	0.449	0.633	0.524	0.134
	ADMS 4.0	0.63	0.53	0.37	0.70	0.488	0.633	0.458	0.032
	ISC-Prime	0.7	0.37	0.3	0.31	0.779	0.883	0.358	0.398

Table 7 – Statistics for the large building: buoyancy cases S, W and X.

Case	Data	Mean	Sigma	Bias	NMSE	Cor	Fa2	Fb	Fs
1	BRE (obs.)	1.00	0.60	0.00	0.00	1.000	1.000	0.000	0.000
	ADMS 3.3	0.23	0.35	0.77	3.19	0.811	0.022	1.251	0.531
	ADMS 4.0	0.29	0.39	0.71	2.13	0.840	0.089	1.096	0.428
	ISC-Prime	0.53	0.65	0.47	0.79	0.751	0.289	0.616	-0.083
4	BRE (obs.)	1.00	0.65	0.00	0.00	1.000	1.000	0.000	0.000
	ADMS 3.3	0.80	0.62	0.20	0.23	0.815	0.689	0.219	0.051
	ADMS 4.0	0.84	0.68	0.16	0.25	0.795	0.689	0.178	-0.053
	ISC-Prime	0.83	0.73	0.17	0.25	0.822	0.711	0.188	-0.125
9	BRE (obs.)	1.00	0.65	0.00	0.00	1.000	1.000	0.000	0.000
	ADMS 3.3	0.58	0.36	0.42	0.63	0.785	0.511	0.535	0.589
	ADMS 4.0	0.56	0.36	0.44	0.67	0.791	0.378	0.564	0.576
	ISC-Prime	0.59	0.57	0.41	0.48	0.852	0.467	0.517	0.14
15	BRE (obs.)	1.00	0.66	0.00	0.00	1.000	1.000	0.000	0.000
	ADMS 3.3	0.50	0.27	0.50	1.00	0.742	0.378	0.673	0.831
	ADMS 4.0	0.47	0.27	0.53	1.08	0.781	0.333	0.716	0.850
	ISC-Prime	0.55	0.46	0.45	0.56	0.898	0.422	0.582	0.361

Table 8 – Statistics for the large building: roof openings 1, 4, 9 and 15.

Data	Mean	Sigma	Bias	NMSE	Cor	Fa2	Fb	Fs
BRE (obs.)	1.00	0.64	0.00	0.00	1.000	1.000	0.000	0.000
ADMS 3.3	0.53	0.47	0.47	0.85	0.678	0.400	0.620	0.316
ADMS 4.0	0.54	0.49	0.46	0.80	0.689	0.372	0.597	0.260
ISC-Prime	0.62	0.62	0.38	0.49	0.796	0.472	0.463	0.028

Table 9 – Statistics for the large building.

4.2 Small building

Figure 4 gives the 5th, 25th, 50th, 75th and 95th percentiles of the ratio of modelled to experimental values for all runs divided into buoyancy cases. **Figure 5** gives shows the same set of results, but separated into number of roof openings.

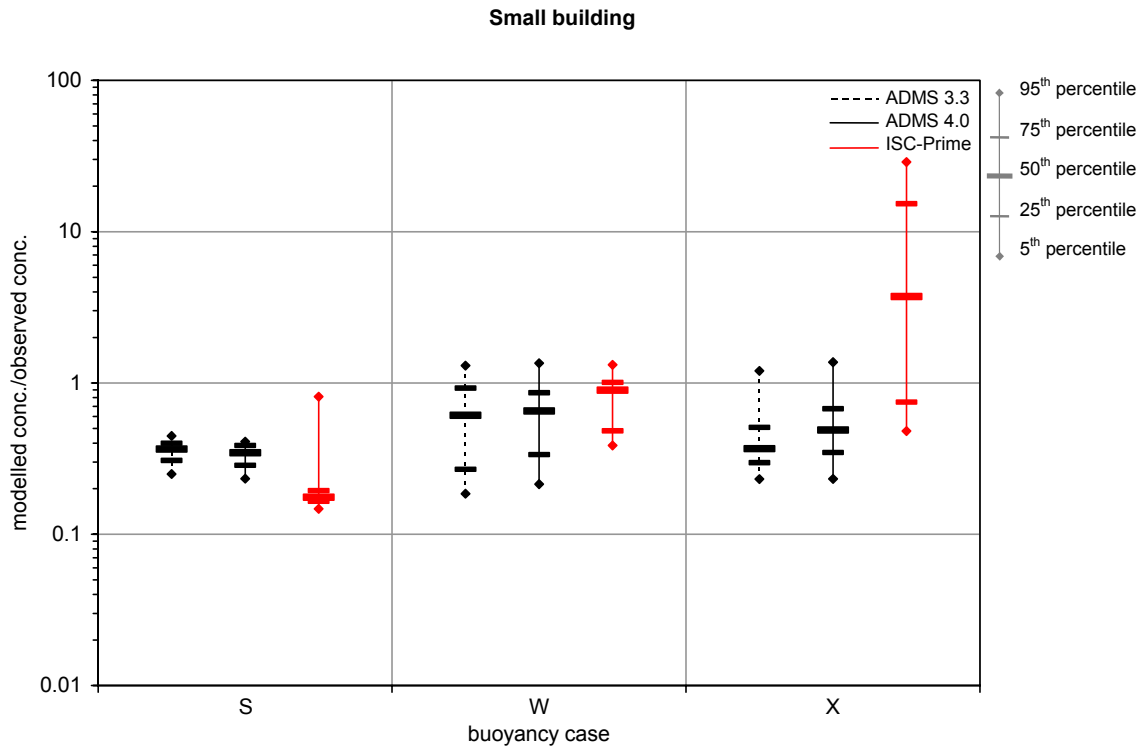

Figure 4 – Box and whisker plot of the results for the small building: buoyancy cases.

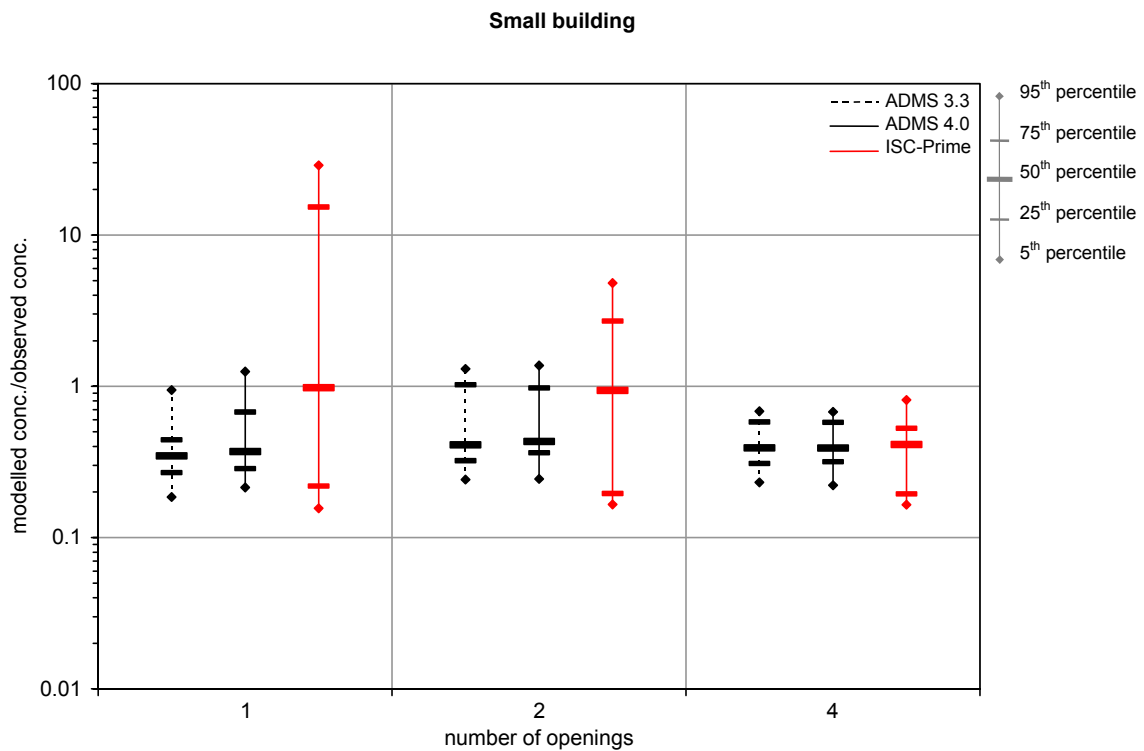

Figure 5 – Box and whisker plot of the results for the small building: roof openings.

Other statistics such as mean, variance (σ), bias, normalized mean square error (NMSE), correlation (cor), values within a factor of 2 of the experimental values ($fa2$), fractional bias

(fb) and fractional standard deviation (fs) are presented in the next tables, as output directly from the BOOT statistics package. **Table 10** gives the statistics divided into the buoyancy cases and **Table 11** gives the values divided into the number of openings. **Table 12** gives the summary statistics.

Case	Data	Mean	Sigma	Bias	NMSE	Cor	Fa2	Fb	Fs
S	BRE (obs.)	1.00	0.94	0.00	0.00	1.000	1.000	0.000	0.000
	ADMS 3.3	0.33	0.33	0.67	2.55	0.948	0.000	1.000	0.961
	ADMS 4.0	0.31	0.30	0.69	2.95	0.952	0.000	1.054	1.031
	ISC-Prime	0.33	0.53	0.67	2.67	0.75	0.067	1.014	0.562
W	BRE (obs.)	1.00	0.49	0.00	0.00	1.000	1.000	0.000	0.000
	ADMS 3.3	0.64	0.49	0.36	0.51	0.585	0.667	0.432	0.014
	ADMS 4.0	0.70	0.52	0.30	0.40	0.648	0.689	0.359	-0.054
	ISC-Prime	1.33	1.18	-0.33	1.03	0.407	0.4	-0.281	-0.405
X	BRE (obs.)	1.00	0.69	0.00	0.00	1.000	1.000	0.000	0.000
	ADMS 3.3	0.72	1.40	0.28	1.66	0.680	0.222	0.320	-0.685
	ADMS 4.0	0.95	1.98	0.05	2.80	0.644	0.400	0.053	-0.971
	ISC-Prime	0.45	0.4	0.55	1.19	0.75	0.311	0.75	0.577

Table 10 – Statistics for the small building: buoyancy cases S, W and X.

Case	Data	Mean	Sigma	Bias	NMSE	Cor	Fa2	Fb	Fs
1	BRE (obs.)	1.00	0.69	0.00	0.00	1.000	1.000	0.000	0.000
	ADMS 3.3	0.64	1.35	0.36	2.01	0.613	0.156	0.438	-0.646
	ADMS 4.0	0.85	1.94	0.15	3.22	0.572	0.311	0.160	-0.951
	ISC-Prime	5.69	7.51	-4.69	13.84	0.008	0.356	-1.402	-1.663
2	BRE (obs.)	1.00	0.78	0.00	0.00	1.000	1.000	0.000	0.000
	ADMS 3.3	0.65	0.67	0.35	0.78	0.648	0.400	0.427	0.154
	ADMS 4.0	0.69	0.74	0.31	0.72	0.649	0.444	0.364	0.063
	ISC-Prime	1.33	1.18	-0.33	1.03	0.407	0.4	-0.281	-0.405
4	BRE (obs.)	1.00	0.72	0.00	0.00	1.000	1.000	0.000	0.000
	ADMS 3.3	0.41	0.30	0.59	1.42	0.837	0.333	0.830	0.825
	ADMS 4.0	0.41	0.29	0.59	1.47	0.823	0.333	0.837	0.839
	ISC-Prime	0.45	0.4	0.55	1.19	0.75	0.311	0.75	0.577

Table 11 – Statistics for the small building: roof openings 1, 2 and 4.

Data	Mean	Sigma	Bias	NMSE	Cor	Fa2	Fb	Fs
BRE (obs.)	1.00	0.73	0.00	0.00	1.000	1.000	0.000	0.000
ADMS 3.3	0.57	0.89	0.43	1.40	0.556	0.296	0.552	-0.201
ADMS 4.0	0.65	1.23	0.35	1.97	0.489	0.363	0.422	-0.505
ISC-Prime	2.49	4.95	-1.49	10.79	0.058	0.356	-0.854	-1.485

Table 12 – Statistics for the small building.

4.3 Both buildings

Figure 6 gives the 5th, 25th, 50th, 75th and 95th percentiles of the modelled/experimental values, for all runs and both buildings. Other statistics such as mean, variance (sigma), bias,

normalized mean square error (NMSE), correlation (cor), values within a factor of 2 of the experimental values (fa2), fractional bias (fb) and fractional standard deviation (fs) are presented in **Table 13**, as output directly from the BOOT statistics package.

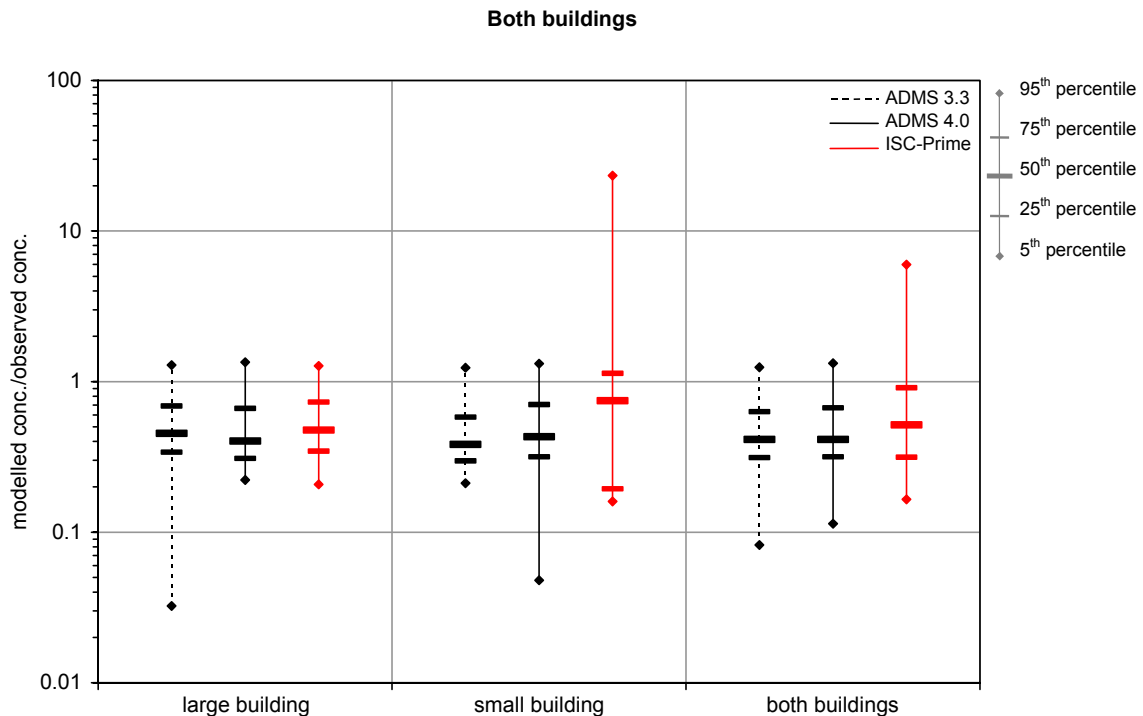

Figure 6 – Box and whisker plot of the results for both buildings.

Data	Mean	Sigma	Bias	NMSE	Cor	Fa2	Fb	Fs
BRE (obs.)	1.00	0.68	0.00	0.00	1.000	1.000	0.000	0.000
ADMS 3.3	0.54	0.68	0.46	1.09	0.584	0.356	0.590	-0.004
ADMS 4.0	0.59	0.89	0.41	1.35	0.517	0.368	0.519	-0.262
ISC-Prime	1.42	3.4	-0.42	8.21	0.117	0.422	-0.35	-1.333

Table 13 – Statistics for both buildings.

5 Summary

General

One would expect results to become less accurate as buoyancy increases from Cases S to W to X. This is because with the increasingly buoyant cases, the plume may pass through the top of the boundary layer and reach the top of the wind tunnel, and then may be reflected back. The behaviour of a plume in the atmospheric boundary layer is different - the fraction of the plume re-entering the boundary layer depends on the temperature inversion at the top of the boundary layer. These experiments demonstrate this – **Figures 2** and **4** show how the spread of modelled/observed results increases with buoyancy. The increase in spread of values for ADMS is less than for ISC-Prime, particularly for the small building; ISC-Prime is seen to under-estimate some values for the high buoyancy case.

In general, all three models perform much the same for the large building, whereas ADMS

(both 3.3 and 4.0) performs better than ISC-Prime for the smaller building. Results also indicate that, with the exception of the '1 opening' case, the large building results agree better with modelled values than the smaller building (compare **Figures 3** and **5**).

The combined results for the large and small building shown in **Figure 6** indicate that while ADMS 4.0 gives generally slightly lower values than ISC-Prime, the spread is less – with the 95th percentile value for ADMS 4.0 being 1.2 compared to 6.0 for ISC-Prime. However, the values contributing to this bad result for ISC-Prime are mainly from the small building most buoyant case experiment (X), and in general ISC-Prime does not over-estimate values. The difference in performance between ADMS 4.0 and ISC-Prime is less when the 5th percentile is considered.

Table 13 gives the summary results from the BOOT package. Comparing the performance of ADMS 4.0 and ISC-Prime, it can be seen that whilst ADMS 4.0 has a better variance, bias, NMSE, correlation and fractional standard deviation, ISC-Prime has a better mean, fractional bias and this model has more values within a factor of 2 of the observed values than either of the other two models.

Large building

Figure 6 the statistics in **Table 9** indicate that overall, ISC-Prime performs slightly better than ADMS 4.0, and both models out-perform ADMS 3.3.

Small building

Figure 6 shows that ADMS 4.0 and ISC-Prime both underpredict compared with the wind tunnel results. ADMS 4.0 underpredicts more than ISC-Prime, but has a much smaller spread of values. Consideration of **Figures 4** and **5** show that whilst ADMS 4.0 generally underpredicts all observed values, ISC-Prime significantly underpredicts for the low buoyancy case S, gives good results for the medium buoyancy case W and significantly overpredicts the buoyant case X. However, **Table 12**, which gives the BOOT summary statistics for the small building, shows that ADMS 4.0 out-performs ISC-Prime for all statistics.

6 References

- [1] Carruthers, D.J., McKeown, A.M., Hall, D.J. and Porter, S., 1999: *Validation of ADMS against wind tunnel data of dispersion from chemical warehouse fires*. In *Atmospheric Environment*, 33, 12, pp. 1937-1953.
- [2] Hall, D.J., Kukadia, V., Walker, S. and Marsland, G.W., 1995: *Plume dispersion from chemical warehouse fires*. BRE Client Report, CR 56/95.
- [3] Hall, D.J., Spanton, A.M., Dunkerley, F., Bennett, M. and Griffiths, R.F., 2000: *An intercomparison of AERMOD, ADMS and ISC dispersion models for regulatory applications*. Environment Agency Technical Report P362.
- [4] Hanna, S.R., 1989: *Confidence limits for air quality models, as estimated by bootstrap and jackknife resampling methods*. In *Atmospheric Environment*, 23, 6, 1385-1398.